

# Vision X AeroTech LED Mini Bars



AERO-85017AC



AERO-85017A

## Beam Patterns

### 6 FLASH PATTERNS

Optional Day/Night mode ensures not to dazzle in low light conditions while being ultra visible during the day.

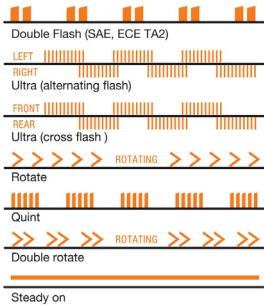

## Line Drawing

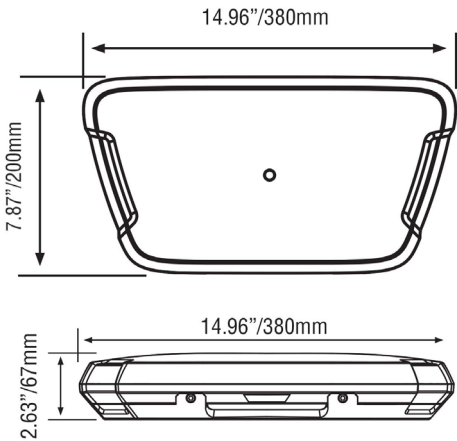

## Description

The AeroTech® range of micro bars has been designed to be the brightest and most visible primary warning lights. This has been achieved with the combination of precision lens optics, high power LEDs along with a unique reflector design to ensure superior visibility day or night. AeroTech® light boxes are engineered to produce uniform, ultra-bright output which meets and exceeds all international standards.

Ultrasonic welding seals the micro bars from water and dust, ensuring an IP67 + IP69K rating. Heavy-duty bases ensure durability in all applications. The polycarbonate lenses themselves, virtually unbreakable, and use a special Makrolon 2607 material which is resistant to UV. Solid state circuitry means no moving parts, so no mechanical failures. This attention to detail enables Vision X to provide a 7-year warranty. These lights really are engineered to go further.

The AeroTech® range has multiple mounting options. With the option to mount via bolts to the cradle, directly to the base or even a magnetic mounting option rated to 74.5mph. They come in 3 different sizes to suit any need, from light commercial up to transport, construction and mining applications. All sizes available in Amber and Clear.

## Features and Benefits

- Vision X's most visible primary warning lights
- Ultra bright, smooth output which meets and exceeds all international standards
- Optional night mode via extra wire
- Ultra durable with extreme vibration resistance
- Versatile, easy mounting
- Available in Amber and Clear

## Applications

Civil and construction, commercial, material handling, industrial, fleets, above ground or below ground mining.

## Tech Specs

LED	84x1.5W LEDs
Flash Patterns	7 Selectable - Rotator (Default), Double Rotate, Double Flash (SAE, ECE TA2), Ultra (cross flash), Ultra (alternating flash), Quint Flash, Steady On
Wattage	126W
Amp Draw	2.1A @12V DC Rotate / 3.7A @12V DC Flash
Operating Voltage	10-80V DC
Operating Temp	-30°C ~ +60°C
Lifespan	50,000 hrs
Housing Material	Polycarbonate Base
Lens Material	Polycarbonate
Shock/Vibration	ISO 16750-3, MIL-STD-810G
Approvals	CE, ROHS, REACH
Ingress Protection	IP67, IP69K
ECE Approval	ECE R65 TA2, ECE R10
EMC Compliance	CISPR25 Class 3
SAE Compliance	J845 Class 1, W3-1
Fixture Weight	4.19 lbs / 1.90kg
Mounting	Cradle, Magnetic (see Parts table below)
Warranty	7 years

Part No.	Description
AERO-85017A	Amber, 84x1.5W LEDs, Cradle, 4.19 lb, 126W, 2.1A Rotate / 3.7A Flash
AERO-85017AC	Clear, 84x1.5W LEDs, Cradle, 4.19 lb, 126W, 2.1A Rotate / 3.7A Flash



Authorised Importer and Master Distributor

**APS USA**  
sales@aps-supply.com  
P: 1 619 263 4164

**APS Australia**  
sales.apsa@aps-supply.com  
P: 61 (8) 9302 2369 (WA)  
P: 61 (02) 4915 6781 (NSW)

**APS Colombia**  
ventascolombia@aps-supply.com  
T: 57 (4) 444 7275

**APS Chile**  
ventaschile@aps-supply.com  
T: 56 (2) 2948 8044

**APS Perú**  
ventasperu@aps-supply.com  
T: 56 (2) 2948 8044

**APS Indonesia**  
techcenter@aps-supply.com



APS Contact Page