

ABL 500 LED Blue/Red

Forklift Warning Light

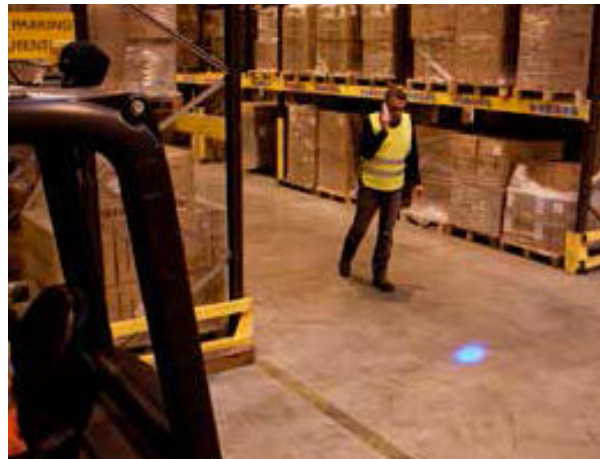

Description

The ABL 500 LED series work lights are designed to exceed everyday demands in all applications. This specific Blue or Red version of ABL's LED worklight range ensures a visible sharp-edged warning signal on the floor for an increased safety environment. This makes it ideal for handling equipment such as forklifts operating in warehouses, stores, storerooms, packing and despatch, etc. A forklift warning light adds a high visibility safety element, which increases safety in the work environment.

Features and Benefits

- Offers a premium safety beam of blue light that produces a distinct visible warning signal on the floor for an increased safety environment
- Designed for inside and outside usage
- Meets IP69K water tightness requirements
- Delivers premium sharp blue spot light optics
- Consumes 5W power
- Includes 12 to 100V multi-volt feature
- Heavy-duty housing achieves IP68 to IP69K, ISO 9227 ratings
- Specific Blue or Red version of the LED worklight range
- Ensures a visible sharp-edged warning signal on the floor
- Increases safety in the work environment
- Provides high visibility safety element for handling equipment such as forklift applications

Applications

Handling equipment such as forklifts

Tech Specs

Bulb	LED Blue, LED Red
Life Time	20,000 Hours
Light Pattern	Sharp Edged Spot
Consumption	5W
Voltage	12-100V DC multi
Intensity	0.2 Amp @ 24V
Weight	1.0 Kg
Vibration Resistance	10 Grms @ 24-2000Hz
EMC	ISO 12 895
Load Dump	130V continuous 200V 100 ms 1800V 50 ms
Polarity	No Polarity
Operating Temp	-40°C to +85°C
Salt Spray	ISO 9227
Connector	AMP 2 pin, DT 2 pin
Mounting	Pedestal, suspended, side mount
Lens	Polycarbonate
Water Tightness	IP68, IP69K

Part No.	Description
LED500BLUE	ABL LED 500 Blue Sharp Edged Spot, 12-100V DC multi
LED500RED	ABL LED 500 Red Sharp Edged Spot, 12-100V DC multi

Mounting

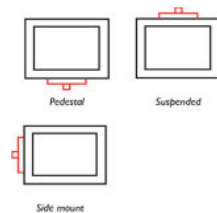

Connections



Options

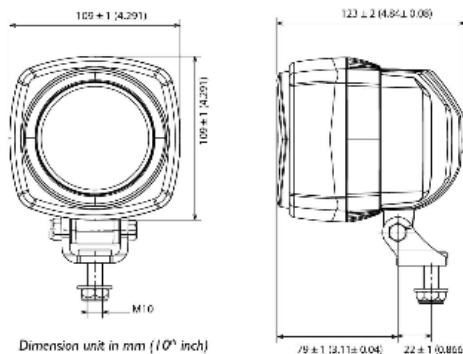

APS USA
sales@aps-supply.com
P: 1 619 263 4164

APS Australia
sales.apsa@aps-supply.com
P: 61 (8) 9302 2369 (WA)
P: 61 (02) 4915 6781 (NSW)

APS Colombia
ventascolombia@aps-supply.com
T: 57 (4) 444 7275

APS Chile
ventaschile@aps-supply.com
T: 56 (2) 2948 8044

APS Perú
ventasperu@aps-supply.com
T: 56 (2) 2948 8044

APS Indonesia
techcenter@aps-supply.com

